

CHEMICAL

OIL & GAS

REFRIGERATION

POWER GENERATION

SERVICE



Convincing worldwide:
HERMETIC pumps
in the refrigeration industry

 **LEDERLE**
Hermetic

Simply the best pump technology

MULTISTAGE CANNED MOTOR PUMPS



General

The CAM und CAMR range of HERMETIC pumps are completely closed. They operate using the canned motor principle which removes the need for any shaft seal. The CAM and CAMR ranges have been developed especially for the refrigeration applications, their features include:

- low NPSH values
- pump built in two to six stages to suit the application
- able to pump 14 m³/h with a suction head of only 0.3-0.5 m
- suitable for pumping ammonia, CO₂, freons and other refrigerants
- the machines were examined by several classification companies and also have approval for use on ships

The CAMR range is a special version of the CAM 2 range designed for compact plants with small collecting vessels.

The design enables:

- space saving by mounting the pump directly under the vessel
- escaping of gas through the suction port, allowing shorter re-starting times
- the hydraulic data and NPSH value are identical to the CAM 2

Design

The pumps use multistage impeller mounted directly on an integral induction motor.

Operating range

Capacity Q: max. 35 m³/h

Head H: max. 170 m.c.l.

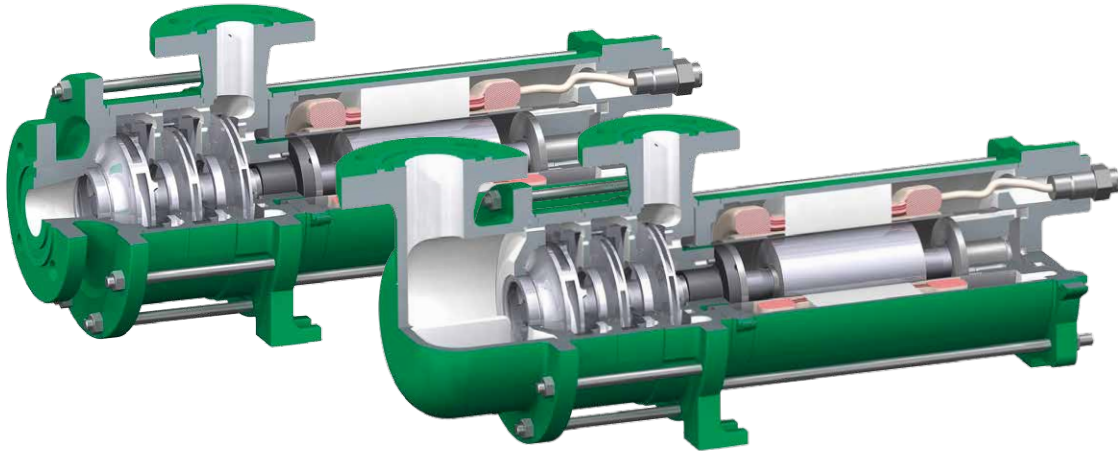

Operation

The partial current for the cooling of the motor and for the lubricating of the bearing is taken from the last impeller on the discharge side and led through the motor space. It is led back through the sleeve shaft not to the suction side of the pump but between two impellers in a region with increased pressure. The point 3, which corresponds to the highest heating in the pressure-temperature-diagram, is sufficiently distanced from the vapour diagram, in order to avoid a boiling out inside the pump.

Bearings

Slide bearings are lubricated by the processed liquid radially guide the pump shaft and the rotor shaft. This guiding, however, takes place only during the starting phase and the stopping phase, since the guiding function is hydrodynamically taken over by the rotor after the nominal speed of the canned motor has been reached. The axial thrust of our pumps is hydraulically balanced. The pumps are maintenance-free during operation.

Safety Devices and Monitoring

We recommend to protect HERMETIC pumps against any extreme flow conditions by means of two orifices. Orifice 1 (Q_{\min}) ensures the minimum flow rate required for the dissipation of the motor heat loss. Orifice 2 (Q_{\max}) ensures the minimum differential pressure in the rotor chamber needed for stabilising the hydraulic axial thrust balance and for avoiding the evaporation of the partial flow. Moreover, this orifice prevents an interruption of the flow of discharge if only a certain minimum suction head is available. Alternatively to orifice 2 (Q_{\max}) a constant flow regulator can be installed (see page 22-24).

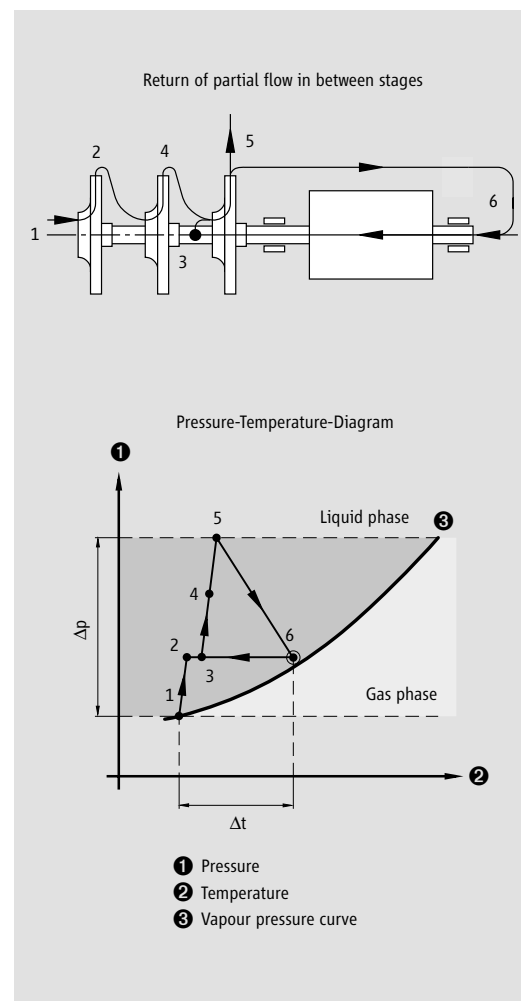
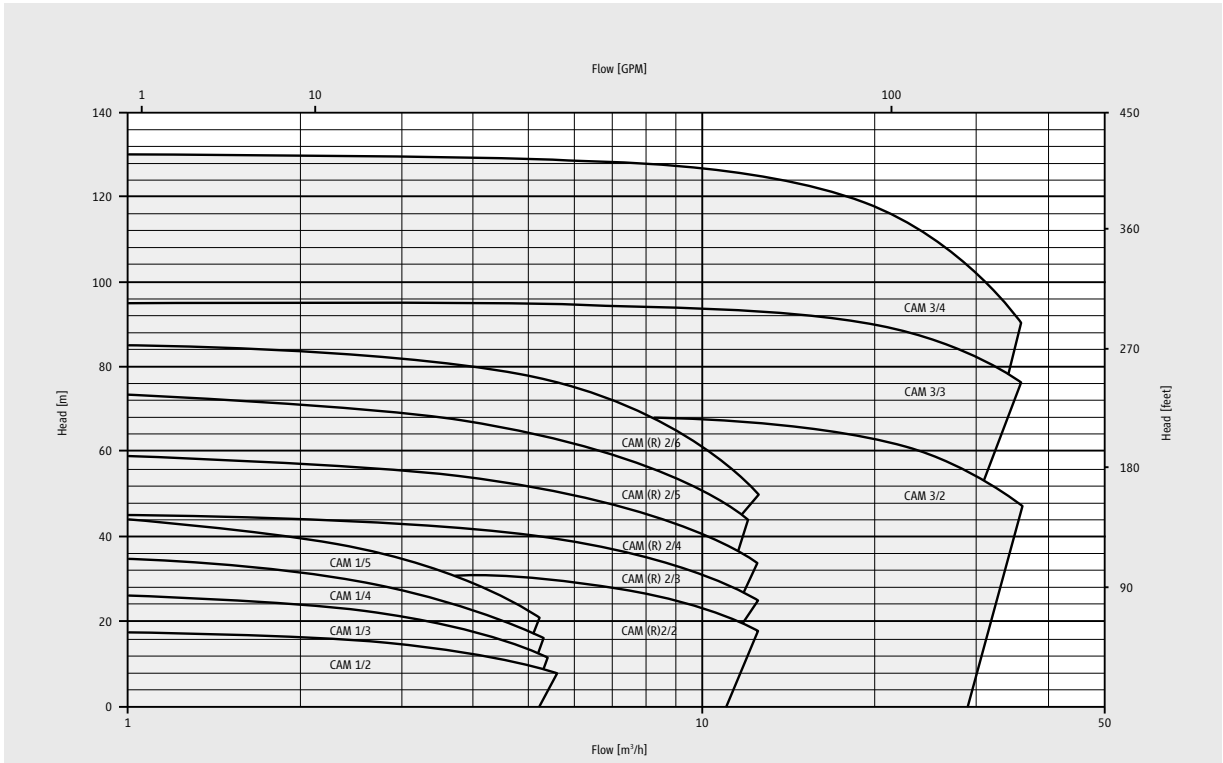
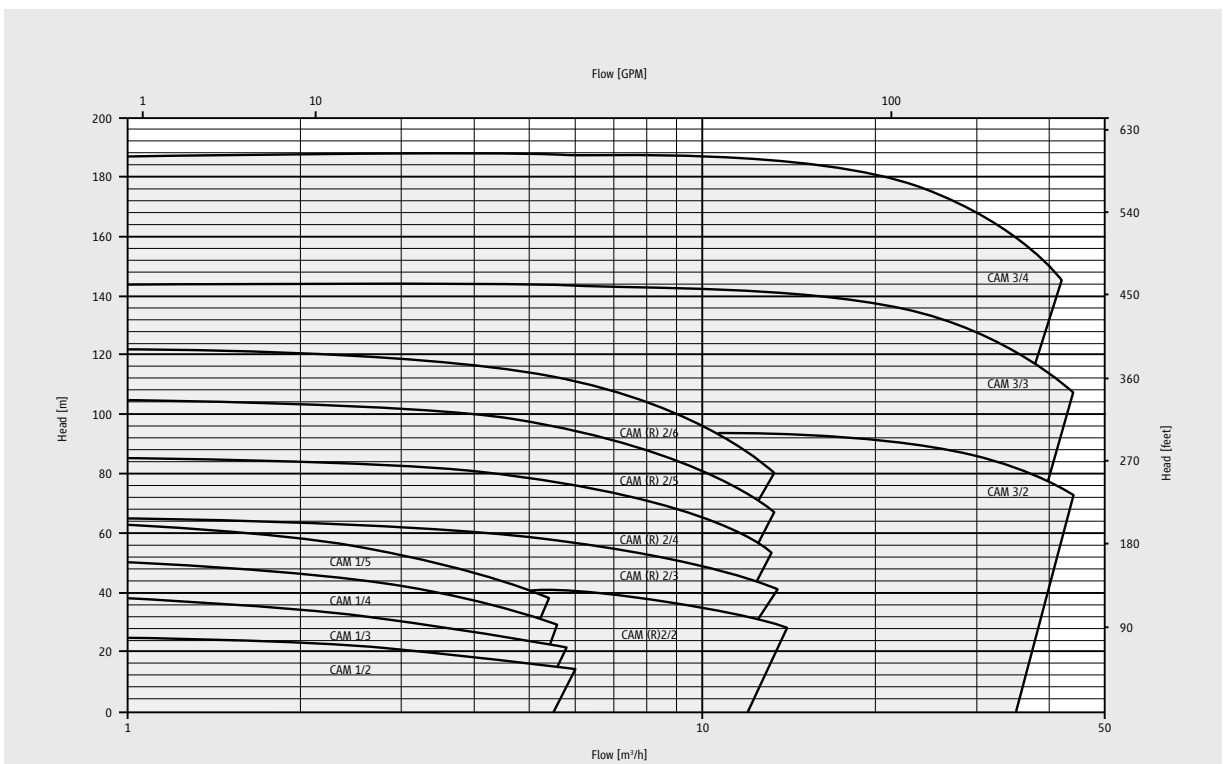

Figure 2

Performance Curve CAM 2900 rpm/50 Hz



Performance Curve CAM 3600 rpm/60 Hz



Materials / Pressure Ratings / Flanges

Casing	JS 1025
Suction cover (Suction casing CAMR 2)	JS 1025
Stage casing (CAM 1, CAM 2, CAMR 2)	1.0460
Stage casing (CAM 3)	JS 1025
Diffuser insert (Diffuser CAM 3)	JL 1030
Impellers	JL 1030
Bearing	1.4021/carbon
Shaft	1.4021
Stator can	1.4571
Gaskets	AFM 34*
Pressure rating	PN 40**, PN 25
Flanges	according DIN EN 1092-1, PN 40 and PN 25 form D

Operating Temperature

Temperature range	-50 °C to +30 °C ***
-------------------	----------------------

Canned Motors

Power	up to 25.0 kW
Rotating speed	2800 rpm or 3500 rpm (frequency regulation possible)
Voltage	220, 230, 380, 400, 415, 440, 460, 500, or 575 Volt
Frequency	50 or 60 Hz
Enclosure	IP 55

* non asbestos

** Test pressure 60 bar

*** further temperatures on demand

CAM / CAMR- Design

Typ	Motor	Pump data		Motor data 50 Hz/ 60 Hz		Weight kg	PN
		Q min. required m ³ /h	Q max. permissible m ³ /h	Power kW	Rated current at 400V/480V		
CAM 1/2	AGX 1.0	0.5	5.0	1.0/1.2	2.7	27.0	40
CAM 1/3	AGX 1.0	0.5	5.0	1.0/1.2	2.7	28.0	40
CAM 1/4	AGX 1.0	0.5	5.0	1.0/1.2	2.7	29.0	40
CAM 1/5	AGX 1.0	0.5	5.0	1.0/1.2	2.7	30.0	40
CAM (R) 2/2	AGX 3.0	1.0	13.0	3.0/3.4	7.1	48.0	40
CAM (R) 2/2	AGX 4.5	1.0	14.0	4.5/5.6	10.4	56.0	40
CAM (R) 2/3	AGX 3.0	1.0	13.0	3.0/3.4	7.1	52.0	40
CAM (R) 2/3	AGX 4.5	1.0	14.0	4.5/5.6	10.4	60.0	40
CAM (R) 2/3	AGX 6.5	1.0	14.0	6.5/7.5	15.2	63.0	40
CAM (R) 2/4	AGX 3.0	1.0	14.0	3.0/3.4	7.1	56.0	40
CAM (R) 2/4	AGX 4.5	1.0	14.0	4.5/5.6	10.4	68.0	40
CAM (R) 2/4	AGX 6.5	1.0	14.0	6.5/7.5	15.2	71.0	40
CAM (R) 2/5	AGX 3.0	1.0	14.0	3.0/3.4	7.1	60.0	40
CAM (R) 2/5	AGX 4.5	1.0	14.0	4.5/5.6	10.4	74.0	40
CAM (R) 2/5	AGX 6.5	1.0	14.0	6.5/7.5	15.2	77.0	40
CAM (R) 2/6	AGX 3.0	1.0	14.0	3.0/3.4	7.1	64.0	40
CAM (R) 2/6	AGX 4.5	1.0	14.0	4.5/5.6	10.4	78.0	40
CAM (R) 2/6	AGX 6.5	1.0	14.0	6.5/7.5	15.2	81.0	40
CAM 3/2	AGX 8.5	6.0	30.0	8.5/9.7	19.0	120.0	40
CAM 3/2	CKPx 12.0	6.0	30.0	13.5/15.7	31.0	150.0	25
CAM 3/3	AGX 8.5	6.0	30.0	8.5/9.7	19.0	138.0	40
CAM 3/3	CKPx 12.0	6.0	30.0	13.5/15.7	31.0	168.0	25
CAM 3/3	CKPx 19.0	6.0	30.0	22.0/25.0	49.5	213.0	25
CAM 3/4	CKPx 12.0	6.0	35.0	13.5/15.7	31.0	186.0	25
CAM 3/4	CKPx 19.0	6.0	35.0	22.0/25.0	49.5	231.0	25

List of parts CAM 1 / CAM 2

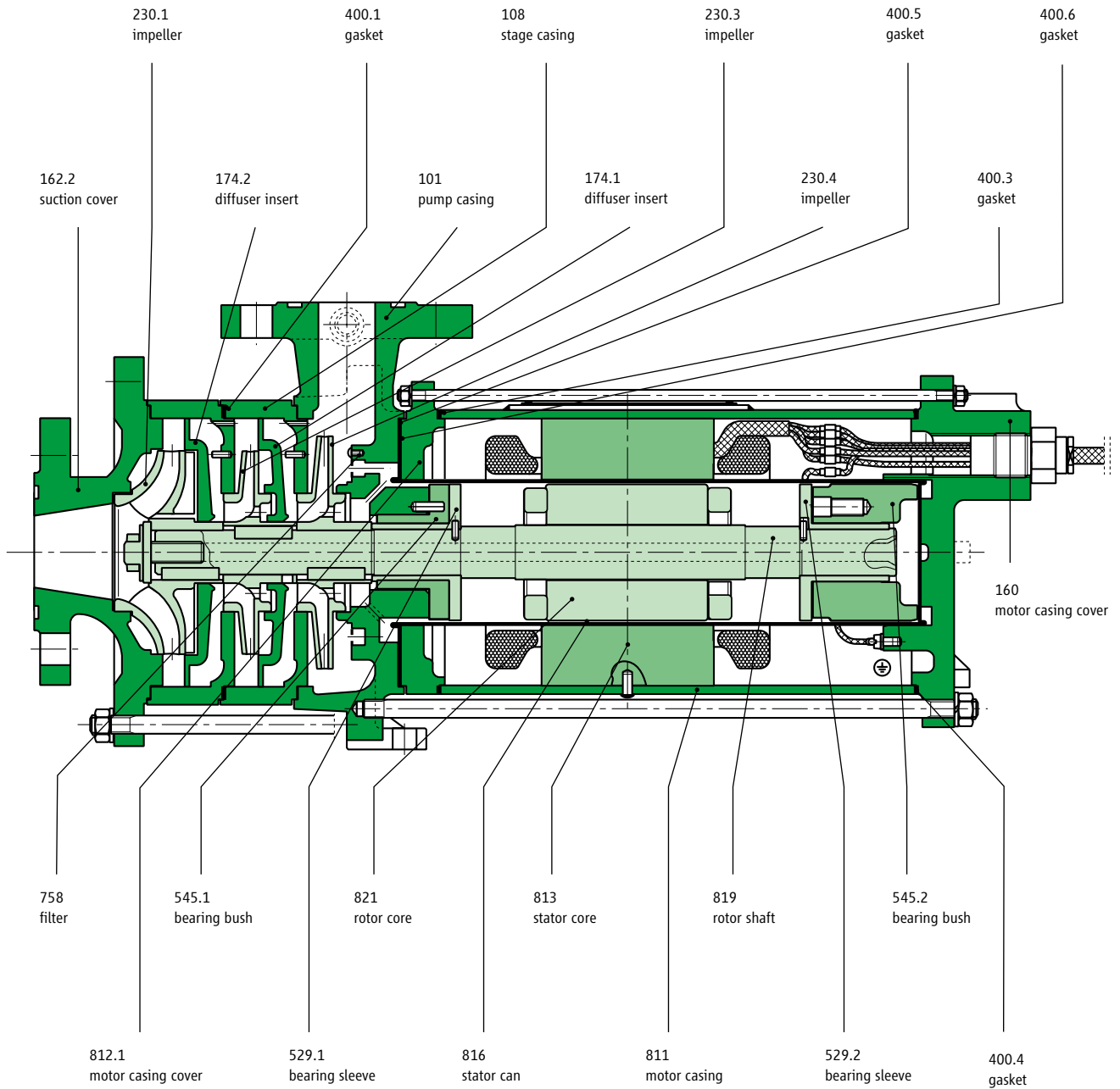

Dimensional drawing for motor type: AGX 1.0 / AGX 3.0 / AGX 4.5 / AGX 6.5

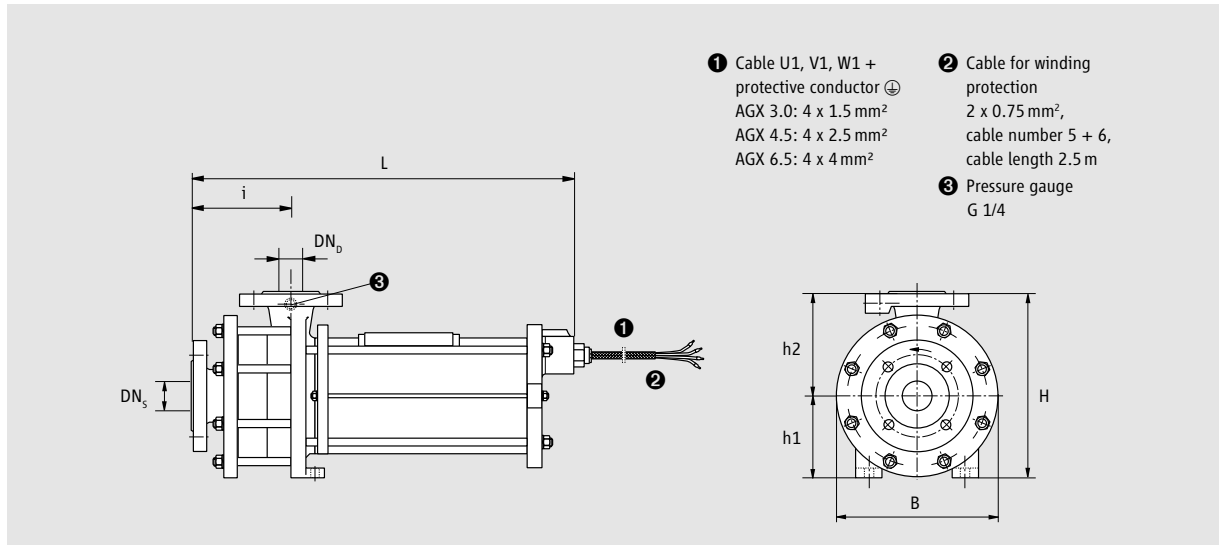

CAM 1-Design

Dimension	CAM	CAM	CAM	CAM
	1/2-stage	1/3-stage	1/4-stage	1/5-stage
	AGX	AGX	AGX	AGX
	1.0	1.0	1.0	1.0
Length/L	419	447	475	503
Width/W	160	160	160	160
Height/H	210	210	210	210
h1	90	90	90	90
h2	120	120	120	120
i	112	140	168	196
DN _s	25	25	25	25
DN _b	20	20	20	20

CAM 2-Design

Dimension	CAM	CAM	CAM	CAM	CAM
	2/2-stage	2/3-stage	2/4-stage	2/5-stage	2/6-stage
	AGX	AGX	AGX	AGX	AGX
	3.0/4.5	3.0 to 6.5	3.0 to 6.5	3.0 to 6.5	3.0 to 6.5
Length/L	536	577	618	659	700
Width/W	218	218	218	218	218
Height/H	250	250	250	250	250
h1	110	110	110	110	110
h2	140	140	140	140	140
i	135	176	217	258	299
DN _s	40	40	40	40	40
DN _b	32	32	32	32	32

List of parts CAMR 2

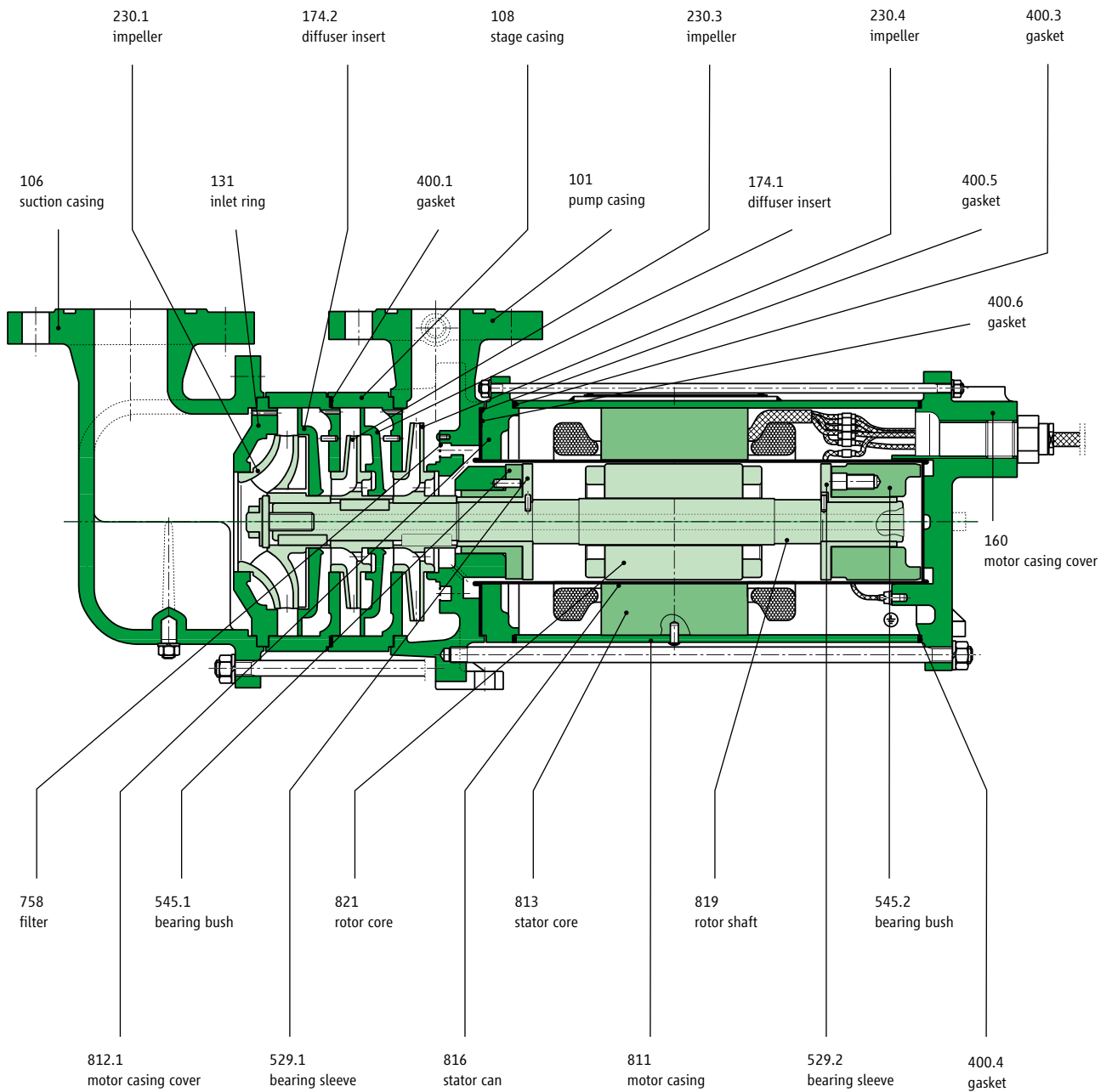

Dimensional drawing for motor type: AGX 3.0 / AGX 4.5 / AGX 6.5

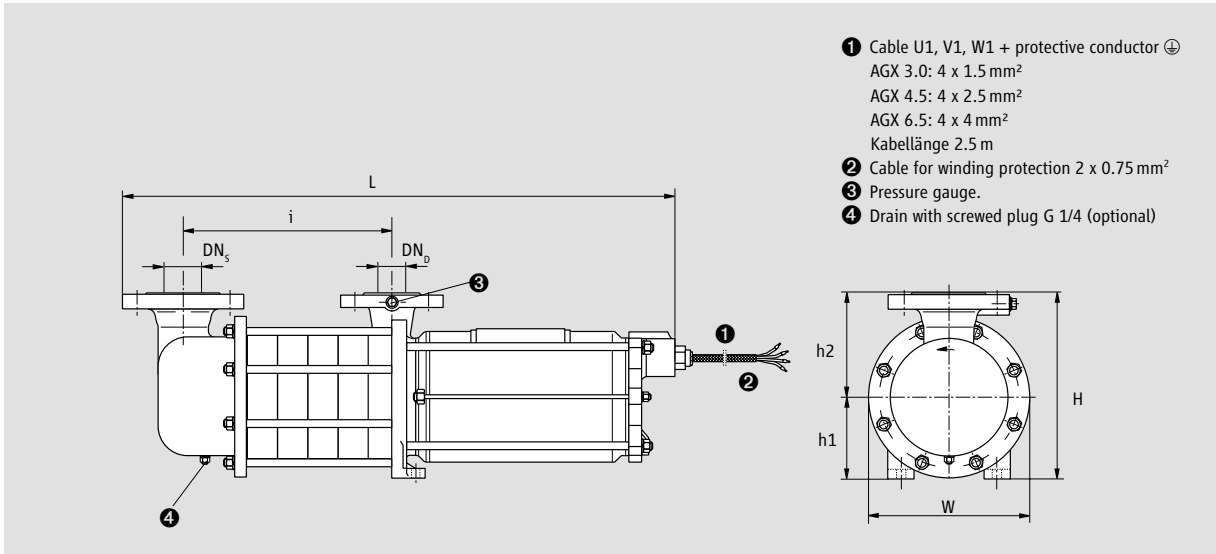

- ❶ Cable U1, V1, W1 + protective conductor ⊕
AGX 3.0: 4 x 1.5 mm²
AGX 4.5: 4 x 2.5 mm²
AGX 6.5: 4 x 4 mm²
Kabellänge 2.5 m
- ❷ Cable for winding protection 2 x 0.75 mm²
- ❸ Pressure gauge.
- ❹ Drain with screwed plug G 1/4 (optional)

CAMR 2-Design

Dimension	CAMR	CAMR	CAMR	CAMR	CAMR
	2/2-stage	2/3-stage	2/4-stage	2/5-stage	2/6-stage
	AGX 3.0/4.5	AGX 3.0 to 6.5	AGX 3.0 to 6.5	AGX 3.0 to 6.5	AGX 3.0 to 6.5
Length/L	649	690	731	772	813
Width/W	218	218	218	218	218
Height/H	250	250	250	250	250
h1	110	110	110	110	110
h2	140	140	140	140	140
i	160	201	242	283	324
DN _s	50	50	50	50	50
DN _b	32	32	32	32	32